



AHT Liftgates LLC
309 Mogie Ln.
Acworth Ga. 30102
727-452-0174
E-Mail: parts@ahtliftgates.com

www.ahtliftgates.com

Spare Parts Catalog

LM-3300 ST/AL
Tailgate Loader
w/Scissor Lift & Hydraulic Legs

Steel Tail Lift w/Aluminum Platform

Item	New Part No.	Old Part No:	Description	Pc's
	LFM1180NRSSASMK	N/A	Tail Lift Assy	1
1	TP0MDRRCX1180UP	N/A	Cross Beam Assy	1
2	FP0SPLA470380XC	N/A	Mounting Bracket (Left)	1
	FP0SPRA470380XC	N/A	Mounting Bracket (Right)	1
3	HP0MSK1180	11105456	Lift Arm Assy (Short)	1
4	ZHS0M55SM	12205405	Lift Cylinder Assy	2
5	ZSS0M55NXX61M	12205452	Tilt Cylinder Assy (Short)	2
6	PA0PWITMJQP141	N/A	Alum Platform w/Roll Stops	1
7	BS0M2	12005826	Pin Assy Kit	1
8	A1E1IU5—B1-	N/A	Power Pack 12 V w/Scissor Body	1
9	EA11150605	11500605	4-Button Control	1
10	RL0PCS1180	N/A	Hydraulic Tubing Assy	1
11	ZL0MP	00000004	Hydraulic Legs	2

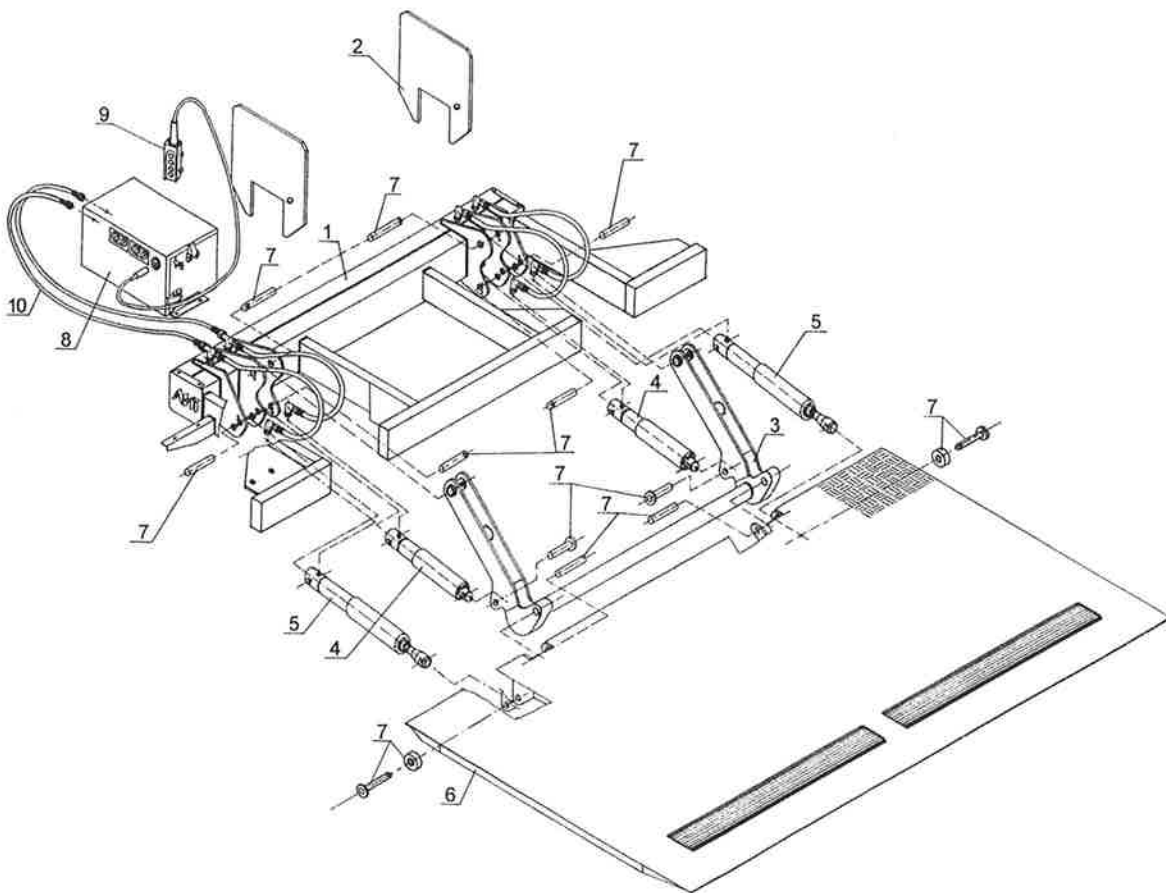

Aluminum Platform w/Roll Stops

Item	New Part No.	Old Part No:	Description	Pc's
1	PA0PWITM3QP141	N/A	Aluminum Platform (Complete)	1
2.1	PA1PIO0205	11300036	Profile, Roll Stop (42")	2
2.2	PA1PHSB0204	11300004	Insert, Roll Stop (39")	2
2.3	K11000103	11000103	Spring, Roll Stop	4
3	PA10600	11000013	Lock, Roll Stop Assy	2
4	PA1P0300	N/A	Bushing Kit	1
5.1	K11000185	11000185	Lock, Platform (Left)	1
5.2	K11000101	11000101	Lock, Platform (Right)	1
6	EA12V0501	11500274	Flashing Light Assy	2
7	PA1SL0950	11000094	Safety Flag	2

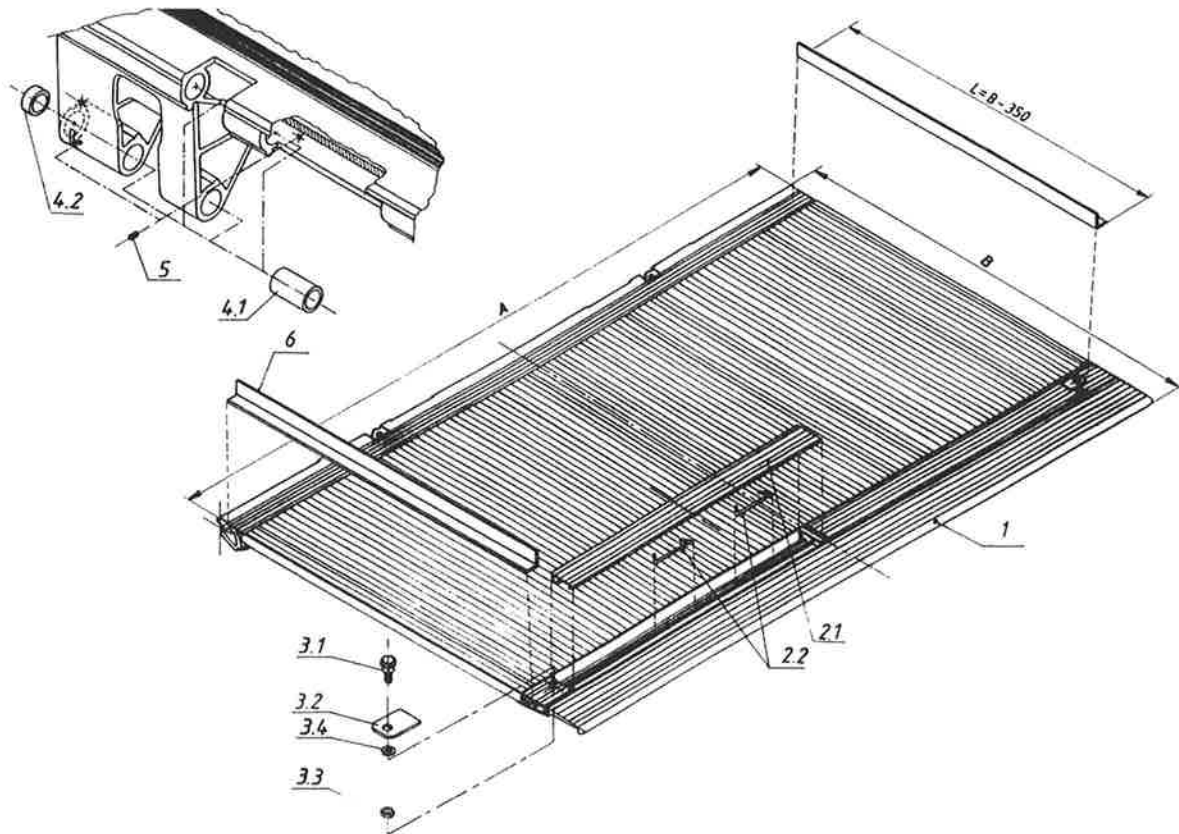

CROSS BEAM

Item	New Part No.	Old Part No:	Description	Pc's
1	TP0MDRRCX1180UP	N/A	Cross Beam Assy (Complete)	1
2	K11000112	11000112	Rubber Grommet	6
3	TS1P0207	12105420	Cover, Cross Beam	2

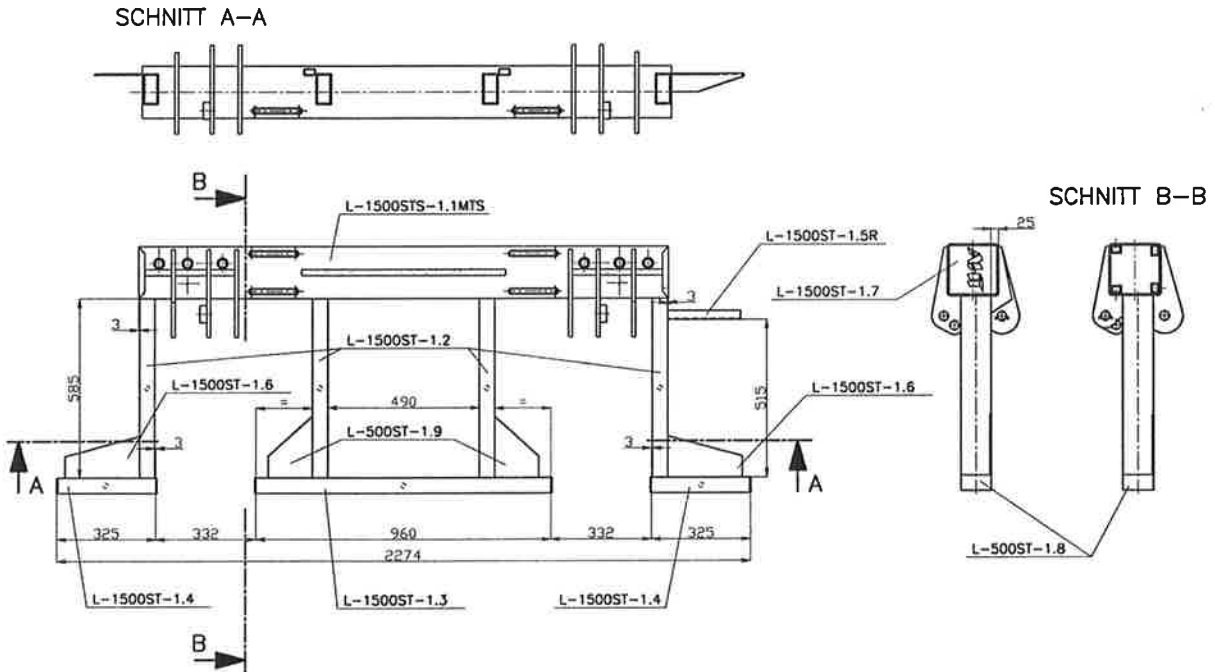

LIFT ARM

Item	New Part No.	Old Part No:	Description	Pc's
1	HP0MSK1180	12105448	Lift Arm Complete (Short)	1
2	K11000105	11000105	Bushing, Rear & Front	8
3	S141241000007	10000090	Grease Fitting	2
4	S141241000099	10000087	Cap, Grease Fitting	2
5	K11000300	11000300	Description Decal	1

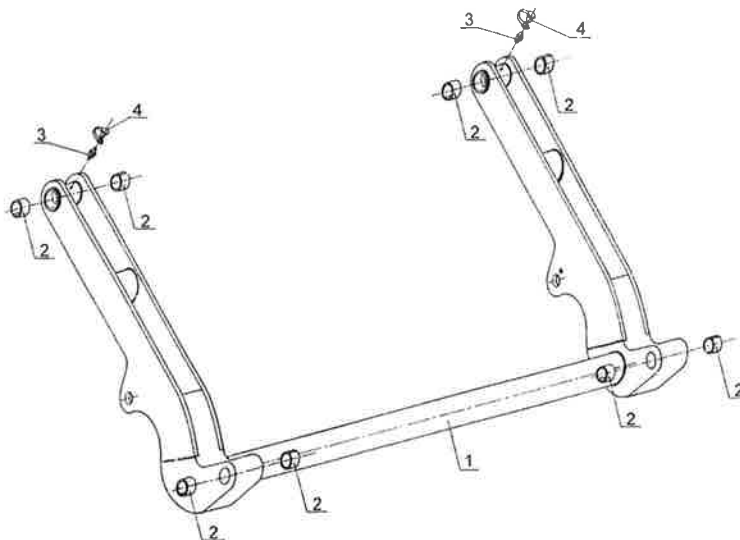

PINS

Item	New Part No.	Old Part No:	Description	Pc's
1	BS0M2	12005826	Pin Assy Kit	1
1.1	BS1PST0200	12005405	Pin, Lift Cylinder-Lift Arm	2
1.2	BS1PAL0300	12005406	Pin, Tilt Cylinder-Platform	2
1.3	BS1PAL0400	12005407	Pin, Lift Arm-Platform	2
1.4	BS1MST0500	12005408	Pin, Lift Cylinder-Cross Beam	2
1.5	BS1MST0600	12005409	Pin, Tilt Cylinder-Cross Beam	2
1.6	BS1MST0500	12005408	Pin, Lift Arm-Cross Beam	2
2	S91281050018	11800022	Cap Screw M6x18	22
3	S12741061002	11800120	Lock Washer o 6	22
4	BS1ST0302	12000052	Locking Bracket	10
5	S141241000007	10000090	Grease Fitting	2
6	S141241100099	10000087	Cap, Grease Fitting	2
7	BS1P0800	12200049	Roller	2

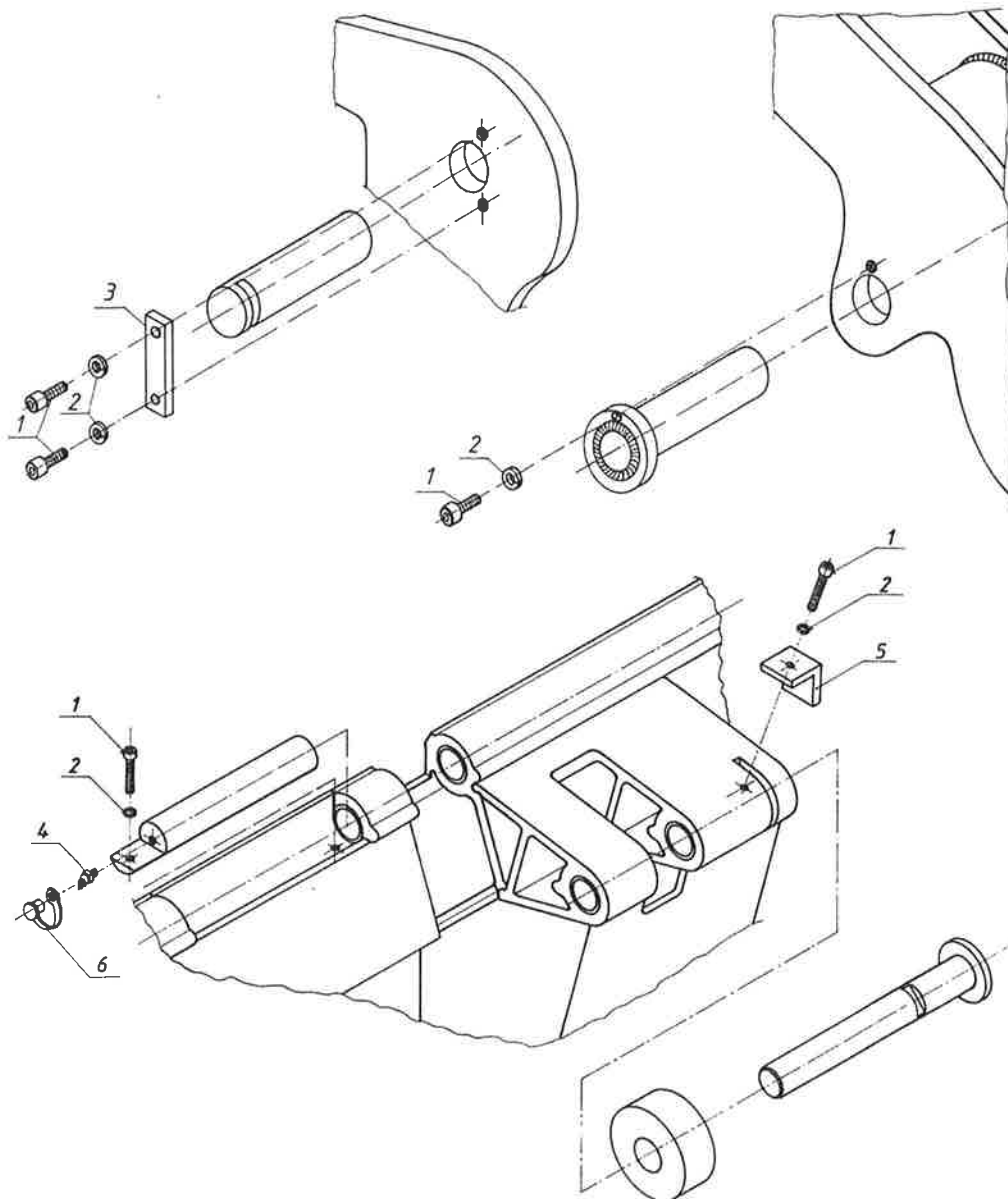

LIFT CYLINDER

w/ Mechanical Hose Burst Valve

Item	New Part No.	Old Part No:	Description	Pc's
	ZHS0M55SM	12205405	Lift Cylinder Assy, Right/Left	2
1	ZHS1MM0200	12205408	Cylinder Tube (Pos 1,3, 4-8)	1
2	ZHS1M0300	12200048	Piston Rod (Pos 2,3,3, 4.1, 5	1
3	K11000105	11000105	Bushing, Cylinder Tube	2
3.1	K11000100	11000100	Bushing, Piston Rod	2
4	S1412411000009	10000091	Grease Fitting 45 degree	1
4.1	S1412411000007	10000090	Grease Fitting	1
5	S1412411000099	10000087	Cap, Grease Fitting	2
6	DH0M55	11600113	Seal Kit, Assy	1
7	AT11400240	11400240	Fitting w/Mechanical. Hose Burst	1
8	RV10700002	10700002	Elbow, 90 degree Fitting	1
9	ZHA1P0400	12200093	Cover, Dust Assy	1
10	S91281050012	11800015	Bolt, Locking Hex	2
11	S12741051002	11800119	Lock Washer	2
12	S12541053000	11800108	Flat Washer	2

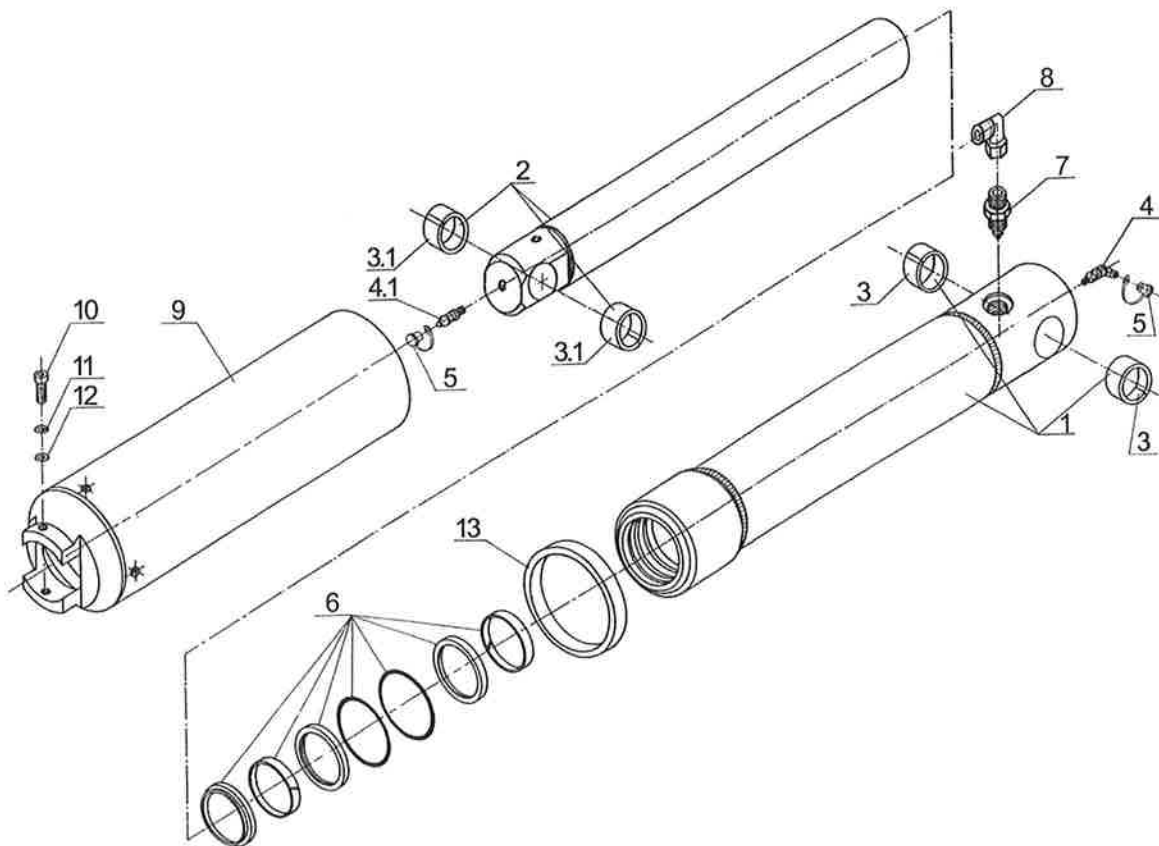

TILT CYLINDER

With Mechanical Hose Burst Valve

Item	New Part No.	Old Part No:	Description	Pc's
	ZSS0M55NXX61M	12205452	Tilt Cylinder, Complete (Short)	2
1	ZSS1MMNX0200	12205458	Cylinder Tube	1
2	ZSA1M0302	12200053	Piston Guide	1
4	ZSA1MK0400	12200062	Clevis w/bushings (Short)	1
5	ZSA1MK0500	12200065	Lock Nut, (Short)	1
6	ZSA1MN0301	12200056	Piston Rod	1
7	ZSA1M0305	12200058	Piston for Opening Spring	1
8	ZSA1M0304	12200072	Opening Spring	1
9	ZSA1M0303	12200061	Nut for Opening Spring	1
10	K11000100	11000100	Bushing, Cylinder Tube	2
10.1	K11000105	11000105	Bushing, Clevis	2
11	DS0M55	11600105	Seal Kit, Assy	1
12	S141241000009	10000091	Grease Fitting 45 degree	1
12.1	S141241000007	10000090	Grease Fitting	1
12.2	S141241000099	10000087	Cap for Grease Fitting	2
13	AT11400240	11400240	Fitting, w/mechanical hose burst	1
15	ZSA1M0600	12200097	Cover, Dust	1
16	ZSA1M610307	12200067	Guide, Piston (Short)	1
17	ZSA1M0306	12200069	Washer, Opening Spring	1
18	S11800013	11800013	Bolt, Locking Hex Head (M4x10)	4

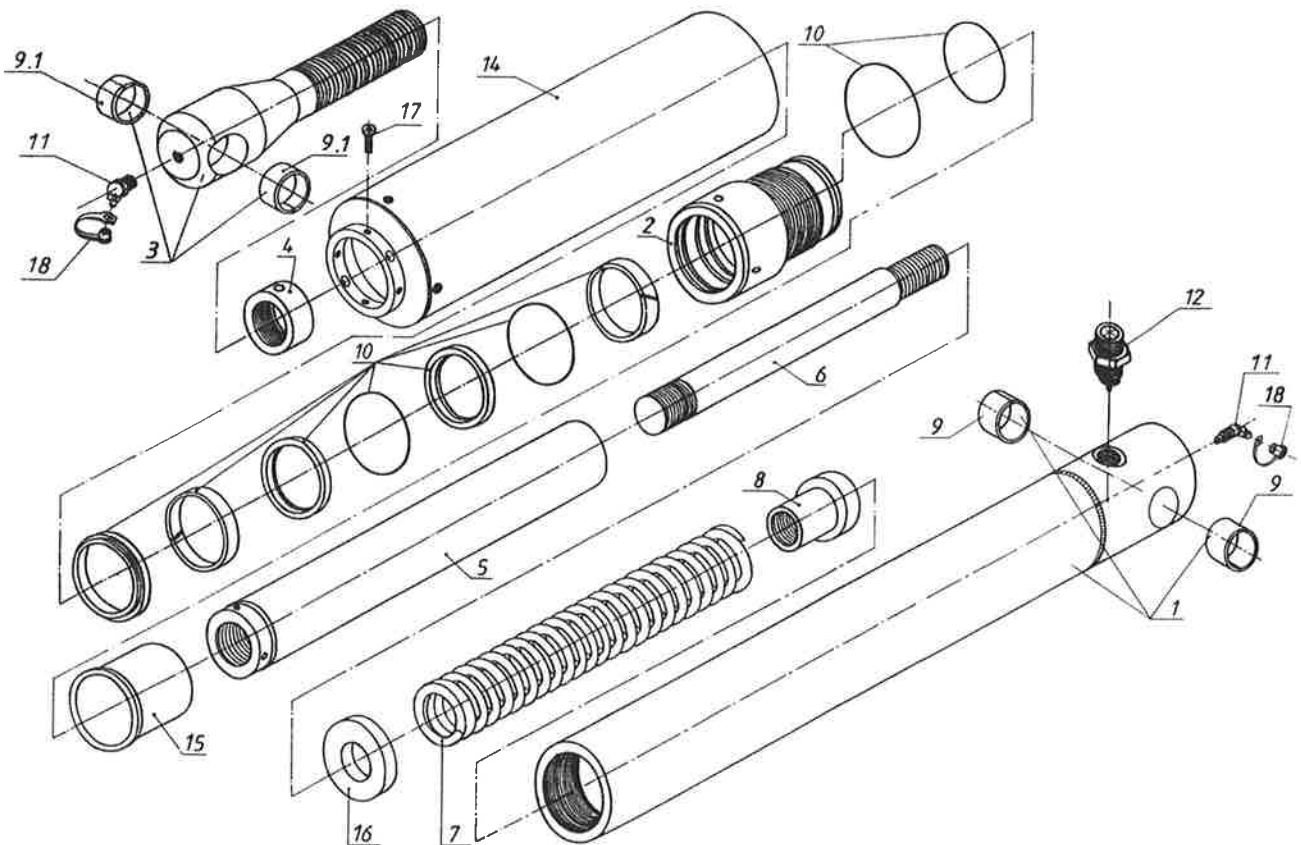

HYDRAULIC LEGS

Item	New Part No.	Old Part No:	Description	Pc's
1	ZL0MP	12210094	Hydraulic Leg Assy	2
2	ZL1M0200	N/A	Cylinder Assy (Middle)	1
2.1	ZL1M0201	12200103	Cylinder Tube (Middle)	1
2.2	ZL1M0202	12200106	Piston Rod	1
2.3	ZL10203	12200100	Pressure Guide	1
4.4	ZSA1D0302	12200005	Piston Guide	1
4.5	DS0D34	11600100	Seal Kit	1
2.6	RV10700006	10700006	Fitting,	1
2.7	RV10700002	10700002	Fitting, Elbow 90 degree	1
3	ZL1M0300	12200298	Tube, Inner Guide Assy	1
4	ZL1MP0400	N/A	Tube, Outer Guide Assy	1
5	ZL1M0500	12200118	Spring	2
6	ZL10600	12200313	Pin	2
7	S12541210000	11800107	Flat Washer M20	4
8	S9441050045	11800179	Cotter Key	4

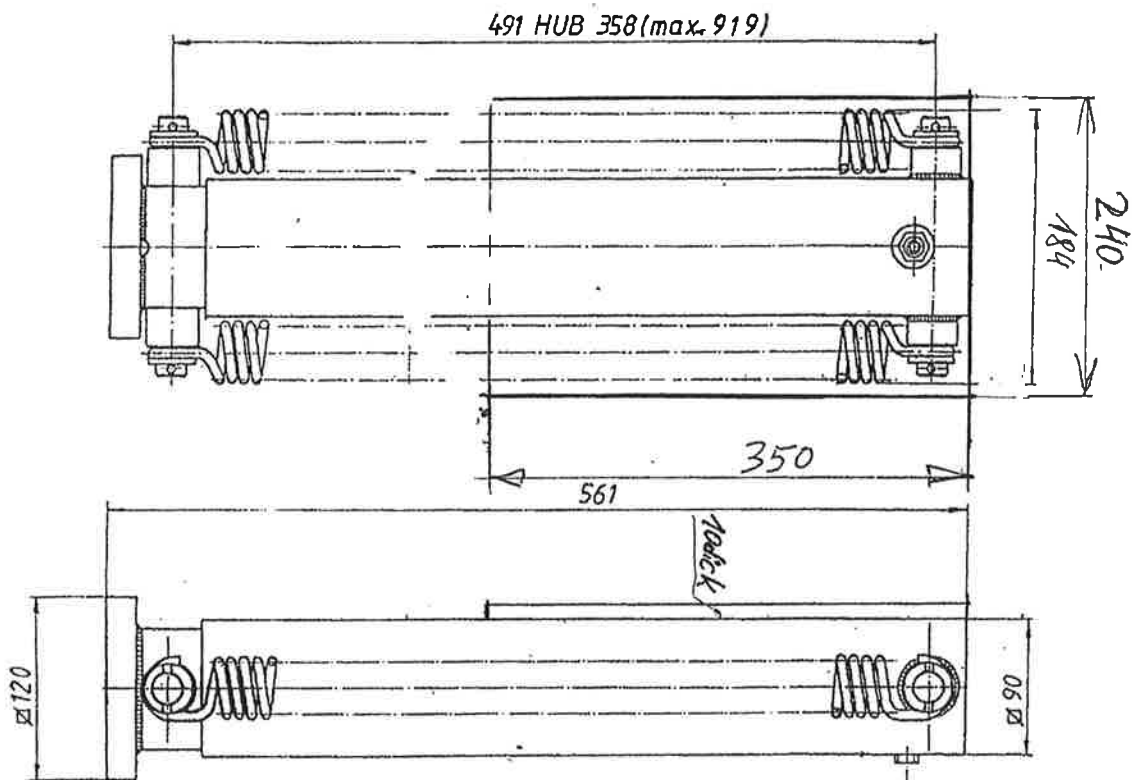

KOLBEN $\varnothing 35$

HUBVOLUMEN 344,43 ccm

TOTVOLUMEN 647,82 ccm

GEWICHT: 13 kg

STÜTZFUSS mittel

STF-1500 M

HYDRAULIC TUBING

Item	New Part No.	Old Part No:	Description	Pc's
	RL0PCS1180	N/A	Hydraulic Tube Assy	1
1	RS1PA11800201	12715420	Hydraulic Tube "Lift"	1
2	RS1PA11800301	12715415	Hydraulic Tube "Tilt"	1
3	RS1PC11800401	N/A	Hydraulic Tube, "Legs"	1
4	RS1NG60750A	11700000	Hose, High Pressure	9
5	RV10700008	10700008	T Fitting	3
6	RV10700002	10700002	Elbow, 90 degree	3
7	RV11700031	11700031	Ferrell	6
8	RV11700030	11700030	Nut	6

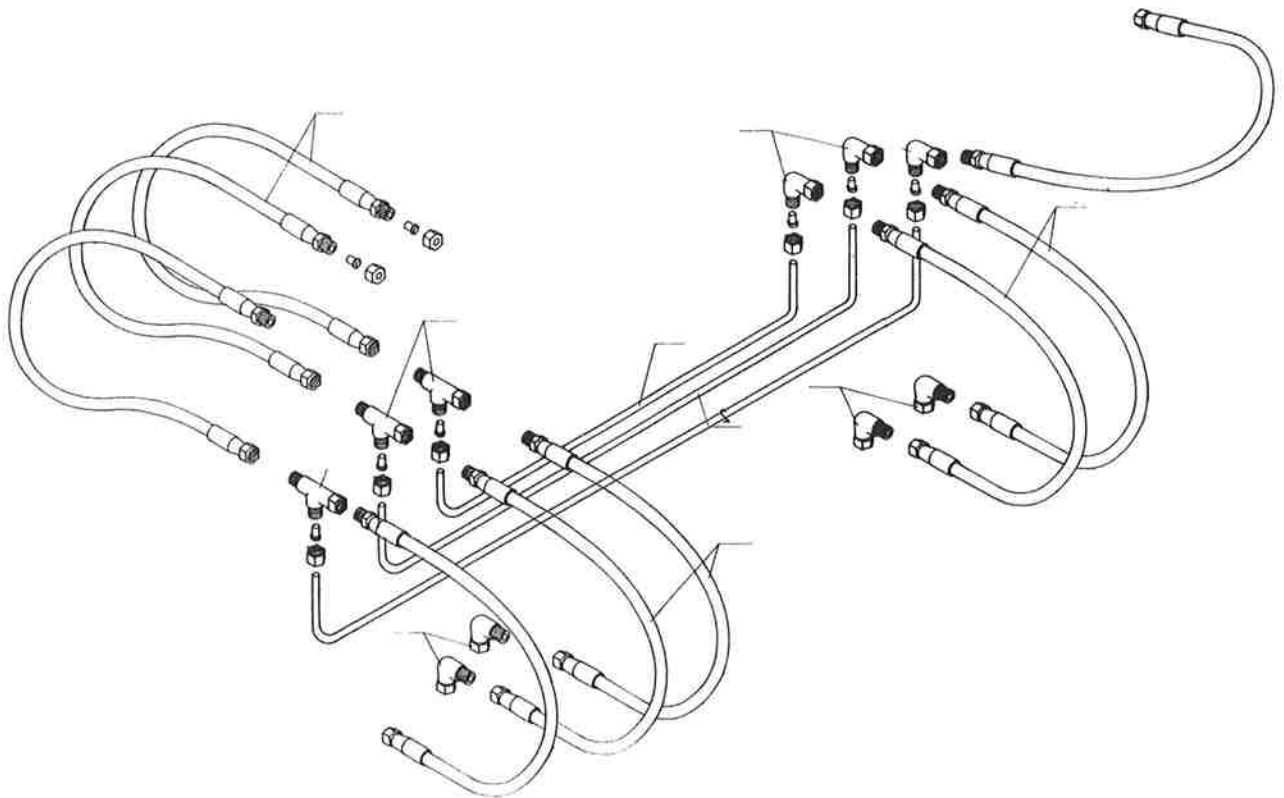

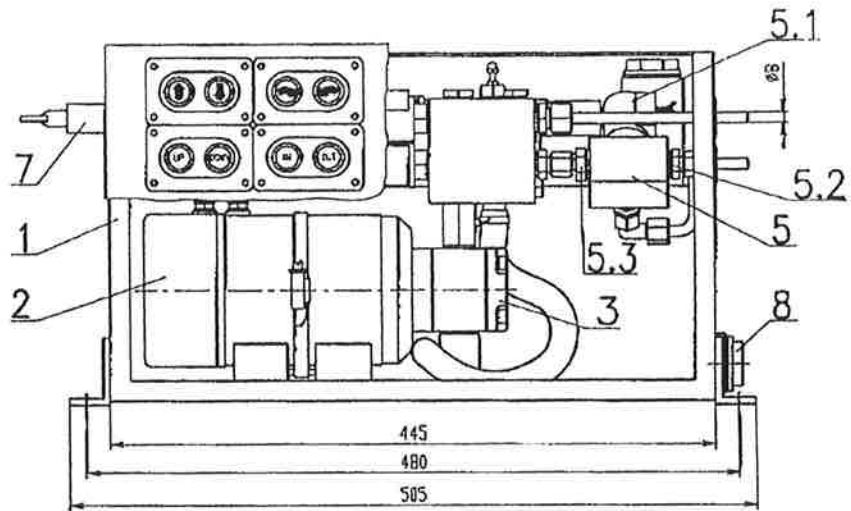

ÜBERLAUFVOLUMEN: 7.6LITER
 OVERFLOW VOLUME

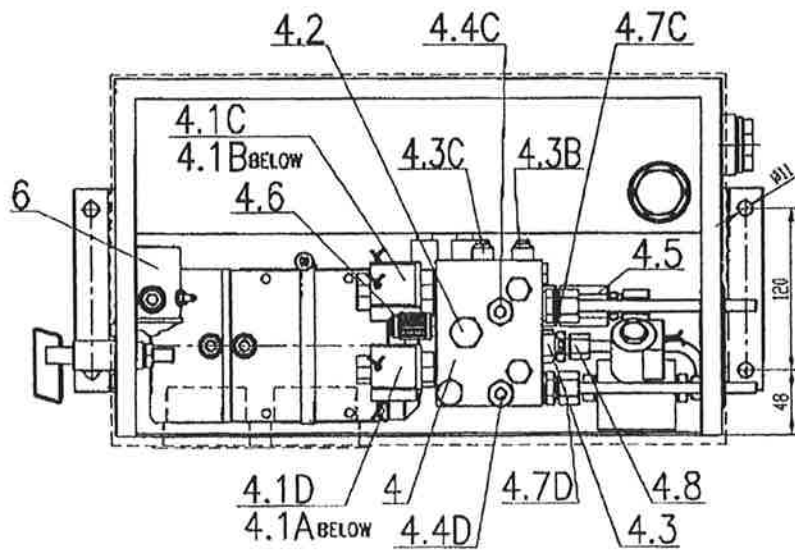

POWER PACK

Item	New Part No.	Old Part No:	Description	Pc's
1	A1E1KU5--B1-	N/A	Power Pack 12 V (Complete)	1
1.1	AT11400221	11400221	Oil Reservoir	1
1.2	AT11400226	11400226	Cover, Power Pack	1
1.3	AT11400014	11400014	Lock, Power Pack	4
1.4	AT11400015	11400015	Bracket, Power Pack Cover	4
1.5	K11000112	11000112	Grommet	6
1.6	AT11400018	11400018	Dipstick, Oil Reservoir	1
1.7	AT11400207	11400207	Filter, Suction	1
1.8	AT11400161	11400161	Extension for Oil Reservoir	1
2	AT11400031	11400031	Motor w/Pump 12V	1
3	AT11400033	11400033	Shuttle Valve	1
4	AT11400242	11400242	Adapter, w/O-Ring	1
5	AT11400036	11400036	Solenoid, Starter 12V	1
6.1	AT11400038	11400038	Clamp, Suction Tube	4
6.2	AT11400039	11400039	Tube, Suction (L=60)	1
6.3	AT11400040	11400040	Tube, Return (L=270)	1
6.4	AT11400042	11400042	Screw, w/O-Ring	1
6.5	AT11400044	11400044	Elbow, Suction w/O-Ring	1
6.6	DO122270	11600158	O-Ring (21x1,5)	1
7.1	AT11400046	11400046	Motor Base	1
7.2	AT11400048	11400048	Clamp, Motor	1
8.1	AT11400150	11400150	Cable, Motor/Starter Solenoid	1
8.2	AT11400151	11400151	Cable, Motor/Oil Reservoir	1
8.3	AT11400152	11400152	Cable, Starter Sol./Battery Switch	1
8.4	AT11400153	11400153	Cable, Battery Switch/Battery	1
9	VB0189R1W3	N/A	Valve Block Assy 12V (Hyd Legs)	1
10	EA111500332	11500332	Cable Connector (10 Pole)	1
11.1	EA111500324	11500324	Battery Switch	1
11.2	EA111500325	11500325	Key for Battery Switch	1
14	EA111500114	11500114	Fuse Holder	1
	EA111500116	11500116	Fuse, 25 Amp (12V)	1
15	VB0209R1W2	N/A	Valve Block Assy 12V (Scissor Lift)	1

MOTOR/PUMP

Item	New Part No.	Old Part No:	Description	Pc's
	AT11400031	11400031	Motor & Pump Assy 12V	1
1	AT11400022	11400022	Motor, DC 12V	1
	AT11400135	11400135	Carbon Brush Kit for 12V	1
2	AT11400026	11400026	Pump Assy	1
3	AT11400093	11400093	Adapter, pump to motor	1
4	AT11400055	11400055	Coupling, pump to motor	1
5	S91281080085	11800128	Cap Screw M8x85	2
6	S12741081002	11800121	Lock Washer	2
7	S12541084000	11800103	Flat Washer	2

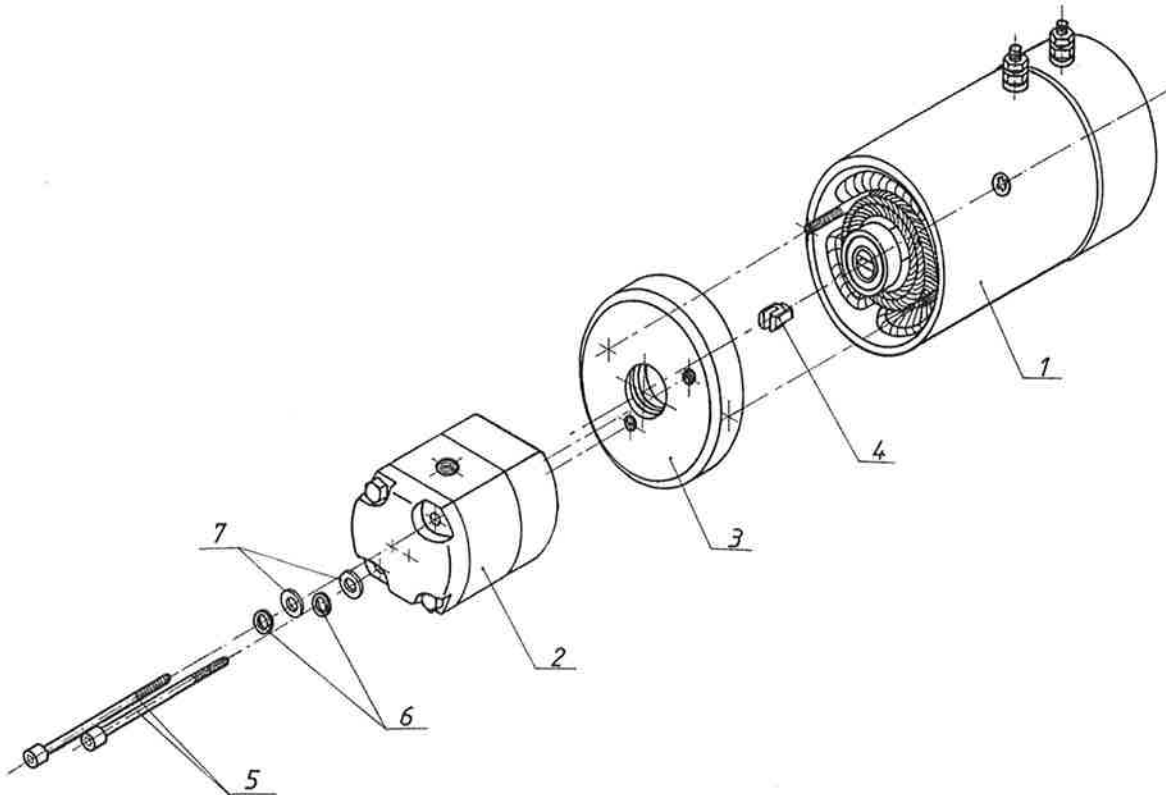

VALVE BLOCK

Item	New Part No.	Old Part No:	Description	Pc's
1	VB0189R1W3	N/A	Valve Block Assy 12V (Hyd Legs)	1
2.2	AT11400063	11400063	Cartridge Valve C-30 12V	4
2.3	AT11400066	11400066	Solenoid, 12 V	4
3	AT11400076	11400076	Wheel Assy	2
4	AT11400083	11400083	Relief Valve	1
5	AT11400077	11400077	Adapter, Pressure Test	1
6	AT11400275	11400275	Shuttle Valve	1
7.1	RV10700009	10700009	Filter, w/Union	2
7.2	AT11400204	11400204	Piston	2
7.3	AT11400205	11400205	Spring	2
8	AT11400079	11400079	Plug, 1/4"	3
9	AT11400078	11400078	Adapter, Return VB-11-6	1
10	AT11400179	11400179	Plug, M8x1	1

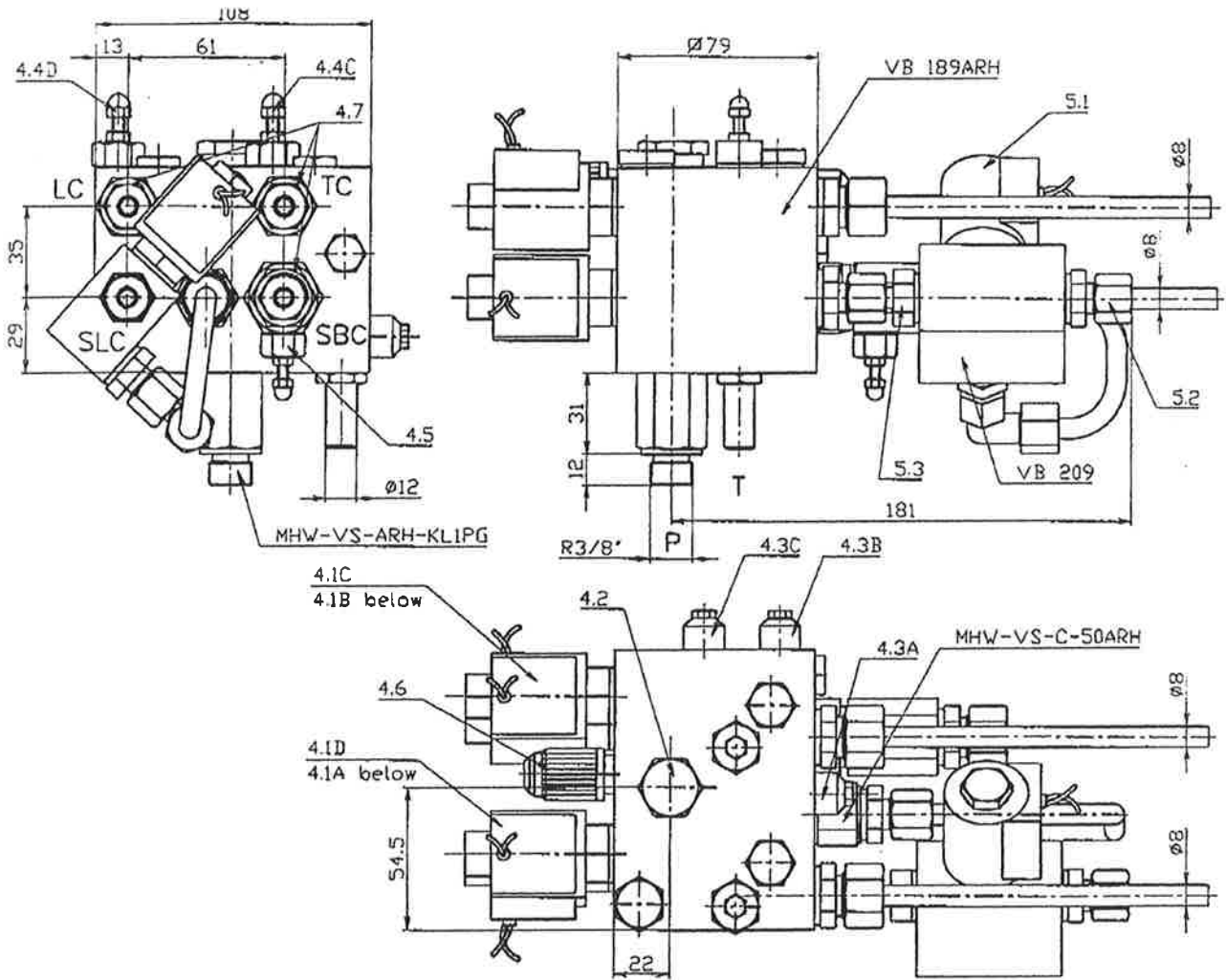

VALVE BLOCK

Item	New Part No.	Old Part No:	Description	Pc's
1	VB0209R1W2	N/A	Valve Block Assy 12V (Scissor Lift)	1
2.2	AT11400064	11400064	Cartridge Valve C-10	1
2.3	AT11400066	11400066	Solenoid, 12 V	1
3	AT11400243	11400243	Throttle Check Valve	1

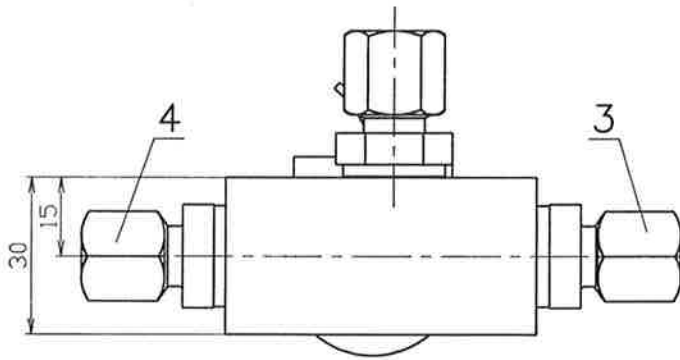

HYDRAULISCHES SCHALTSCHEMA
WIRING SYMBOL

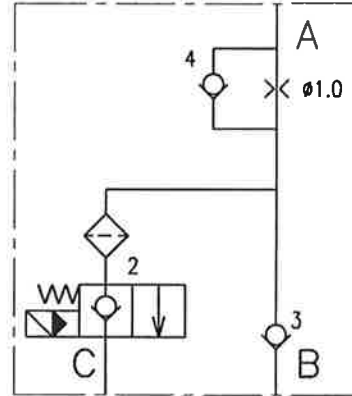

DRUCKANSCHLUSS A R1/4"
DRUCKANSCHLUSS B R3/8"
PRESSURE CONNECTION

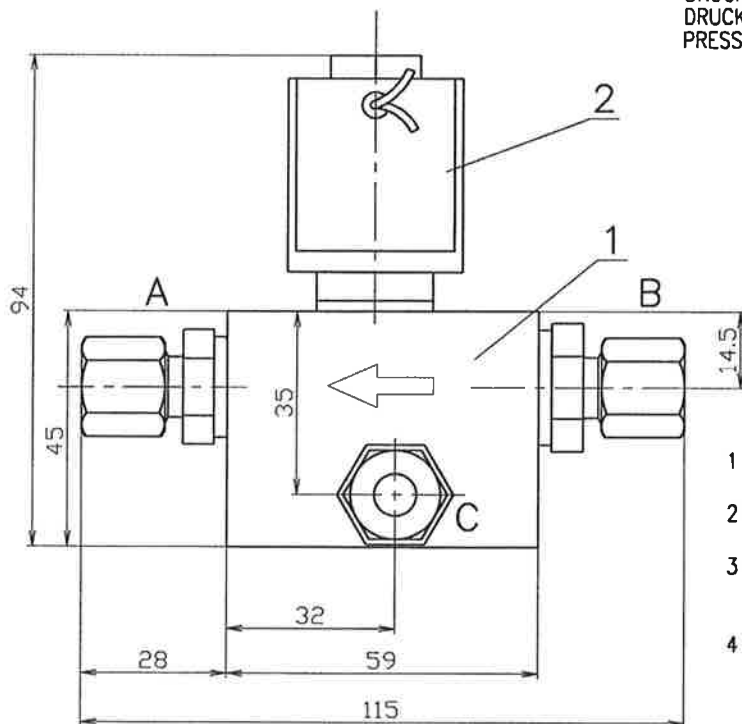

- 1 VENTILBLOCK 209
VALVE BLOCK
- 2 2/2-WEGEVENTIL MHW-C-10F
2/2-WAY VALVE
- 3 RÜCKSCHLAGVENTIL
MHW-RSV-GEB-PL/R3/8-ED
CHECK VALVE
- 4 DROSSELRÜCKSCHLAGVENTIL
MHW-DRSV-11KB
THROTTLE CHECK VALVE

BUTTONS FOR POWER PACK

Item	New Part No.	Old Part No:	Description	Pc's
	AT11400226	11400226	Cover only with switch holder	1
	AT11400226E	11400226	Cover with Holder & Switches	1
1	AT11400260	11400260	Protective Covering (Plastic)	4
2	EA111500645	11500645	Contact Block "Up/Down"	2
	AT111500646	11500646	Contact Block "Open/Close"	2
2.1	EA111500650	11500650	Contact Block	4
2.2	EA111500651	11500651	Cover, Waterproof	4
2.3	EA111500652	11500652	Label, "Up or Down"	6
2.4	EA111500654	11500654	Label, "Close"	1
2.5	EA111500653	11500653	Label, "Open"	1
4	S200039040085	11800197	Rivet (4x8,5)	16
5	S91281040016	N/A	Cap Screw (M4x16)	4

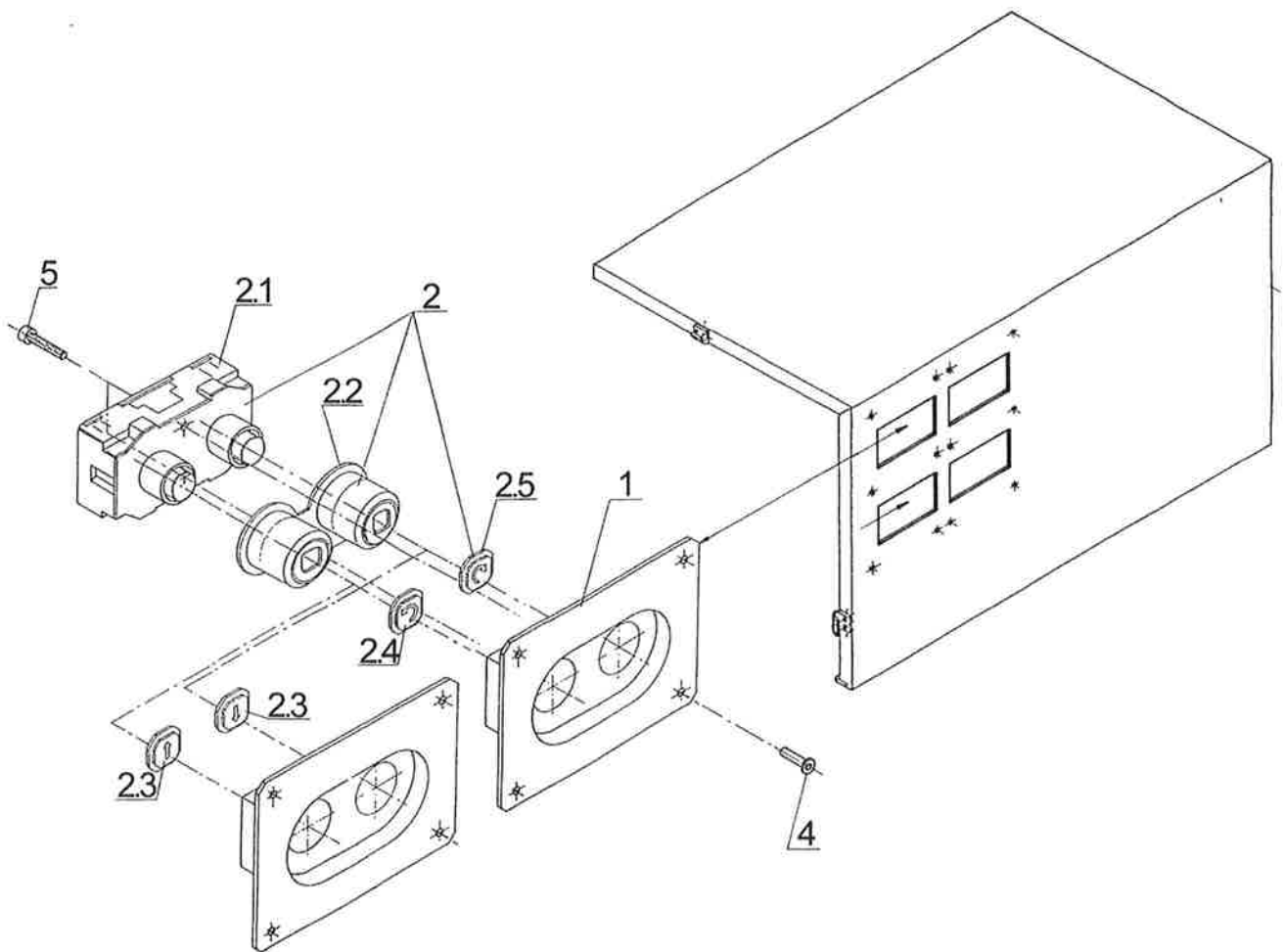

4-BUTTON CONTROL

Item	New Part No.	Old Part No:	Description	Pc's
	EA111500605	11500605	4-Button-Control Assy	1
1	EA111500630	11500630	Housing, 4-Button-Control	1
2.1	EA111500611	11500611	Protector, Cable	1
2.2	EA111500612	11500612	Grommet	1
3.1	EA111500613	11500613	Contact Block	2
3.2	EA111500614	11500614	Label, "Up/Down"	1
3.3	EA111500632	11500632	Label, "Open/Close"	1
3.4	EA111500615	11500615	Screw	4
4	EA111500633	11500633	O-Ring	1
5.1	EA111500617	11500617	Clamp	2
5.2	EA111500618	11500618	Screw	2
6	EA111500072	11500072	Cable for 4-Button	1
7	EA111500066	11500066	Spiral Cable	1

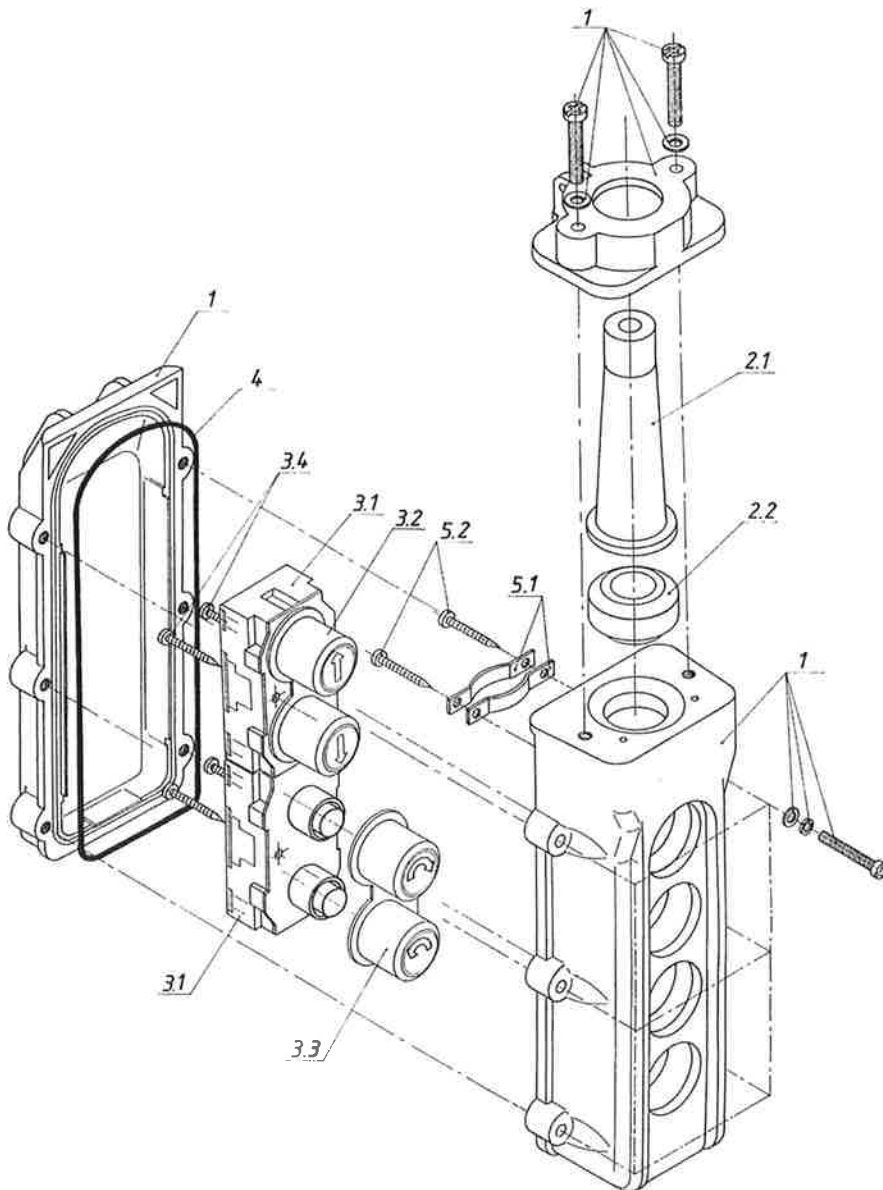

HYDRAULIC SCHEMATIC

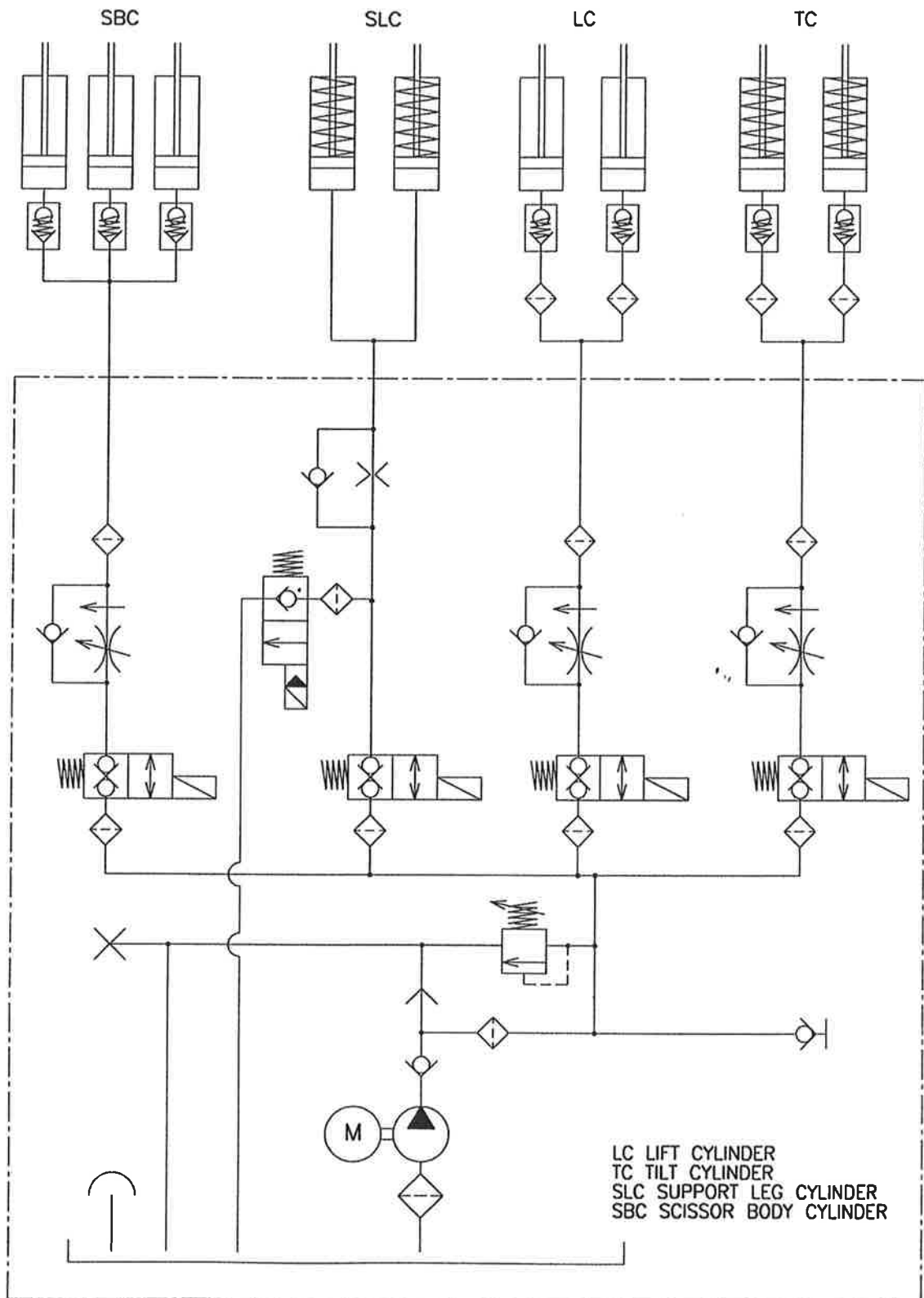

ELECTRICAL SCHEMATIC

