

# HYDRAULIC SCHEMATIC

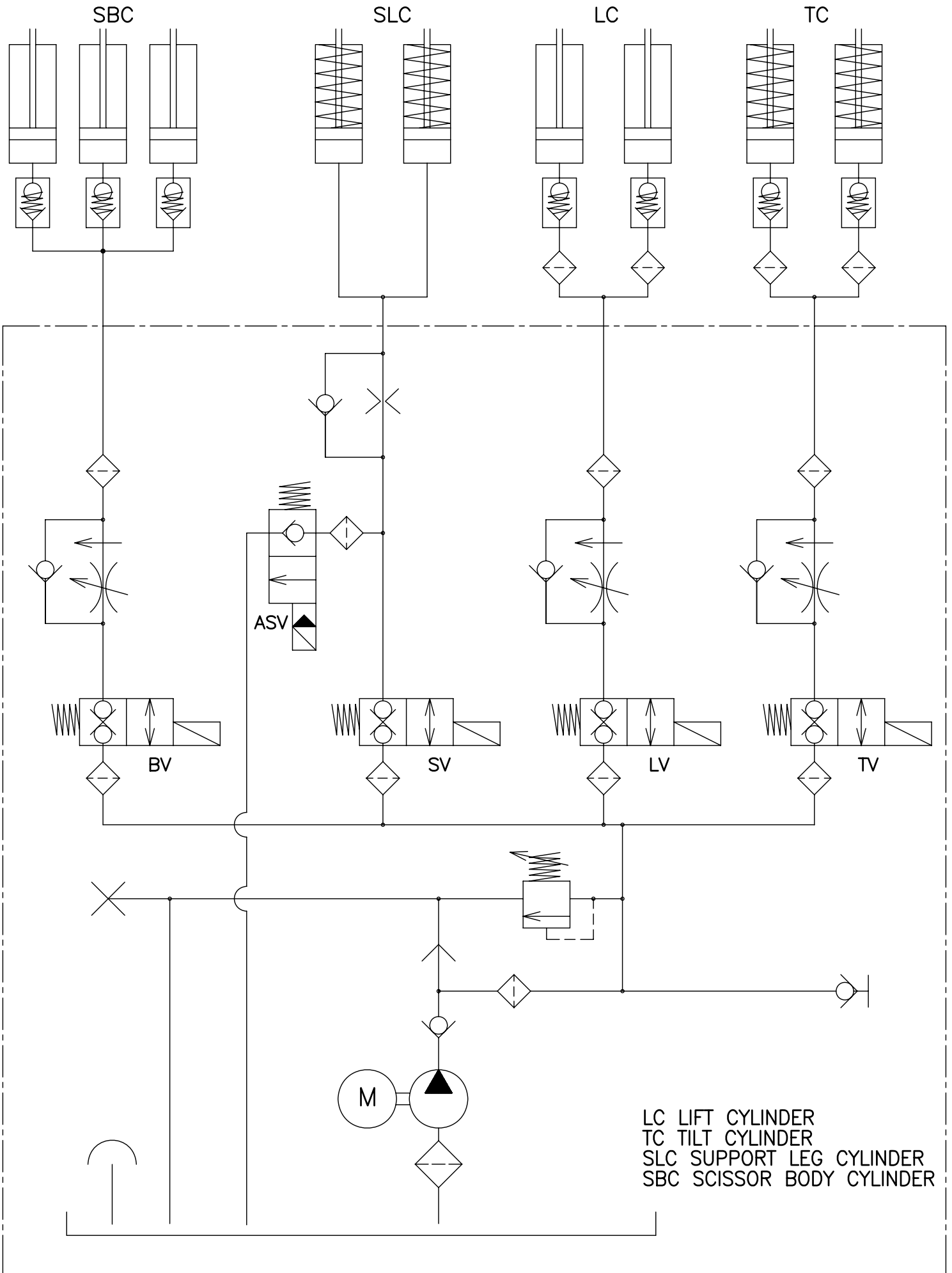

LC LIFT CYLINDER  
TC TILT CYLINDER  
SLC SUPPORT LEG CYLINDER  
SBC SCISSOR BODY CYLINDER

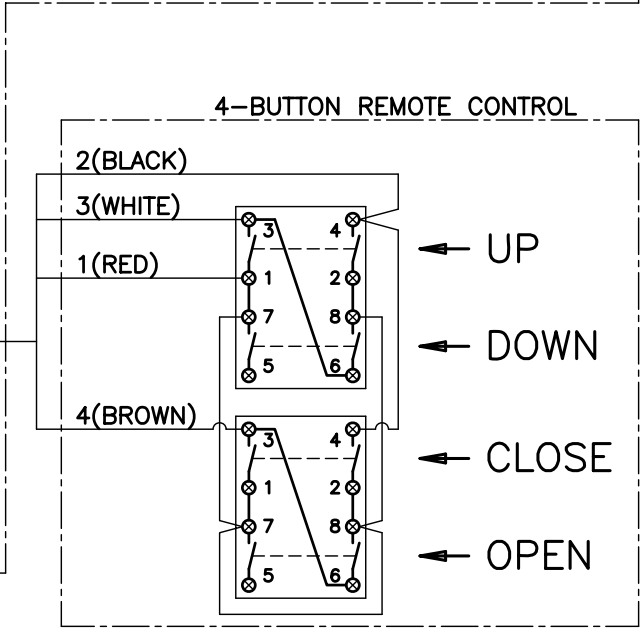
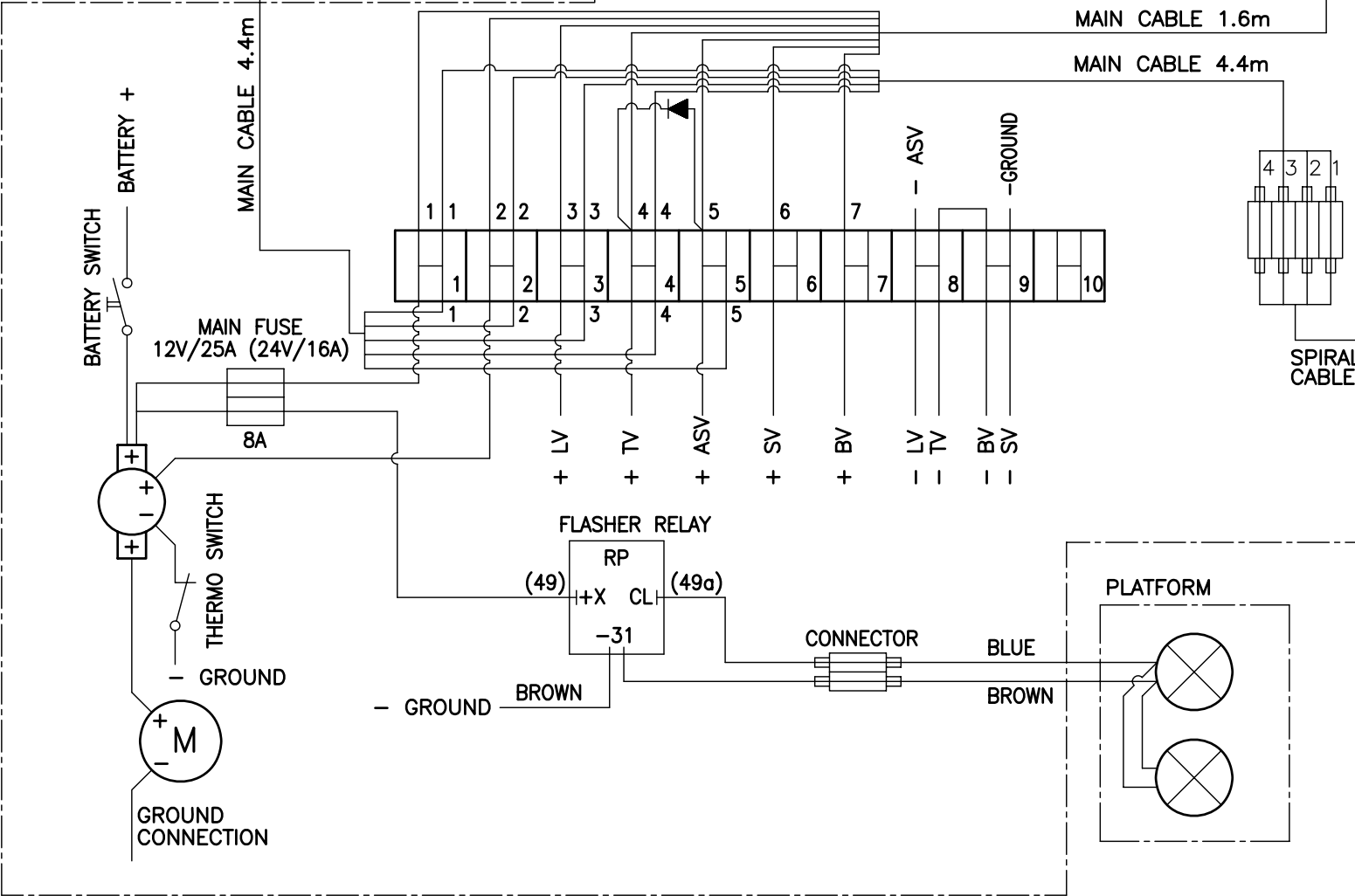
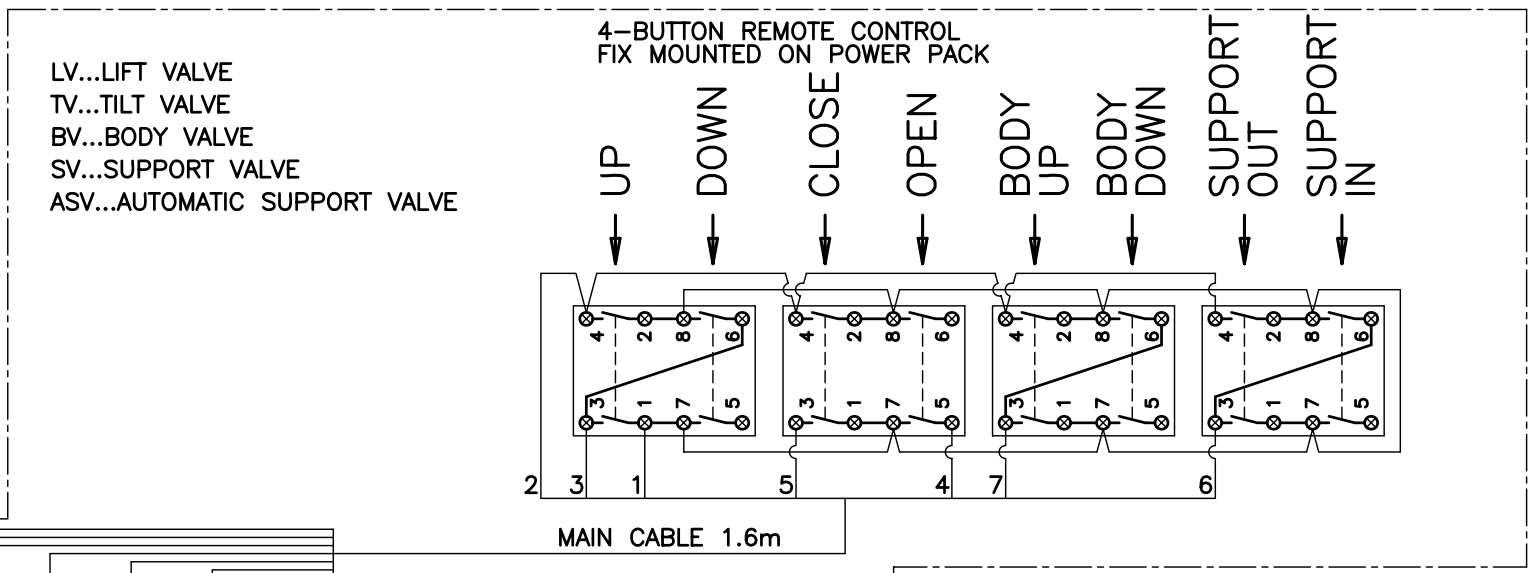
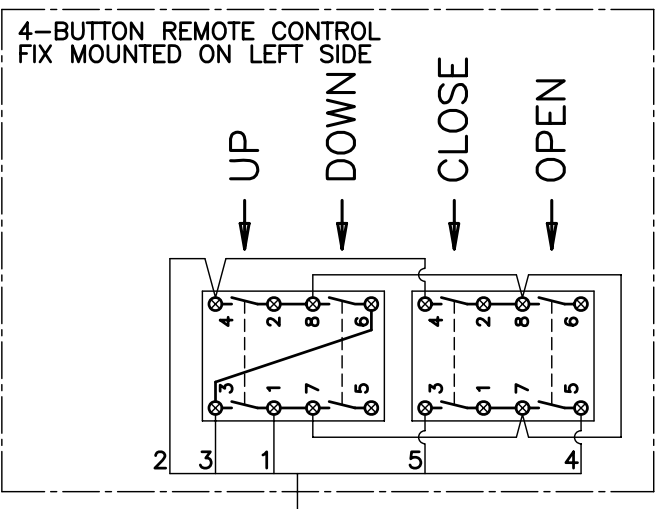

30

ELECTRICAL WIRING DIAGRAM:  
LFSMB2BWC

